



НЕРЖАВЕЮЩИЙ МЕТАЛЛОПРОКАТ

EN 10219-2:2006

30000

НАИМЕНОВАНИЙ ПРОДУКЦИИ



**Специальные
Стали и Сплавы**

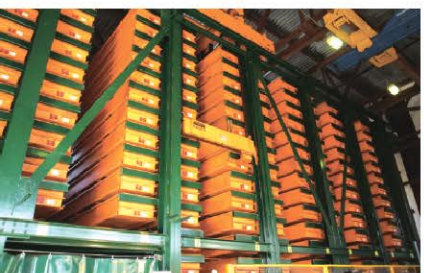

12

СОВРЕМЕННЫХ И АВТОМАТИЗИРОВАННЫХ
СКЛАДОВ, ПЛОЩАДЬЮ БОЛЕЕ

50000 м²

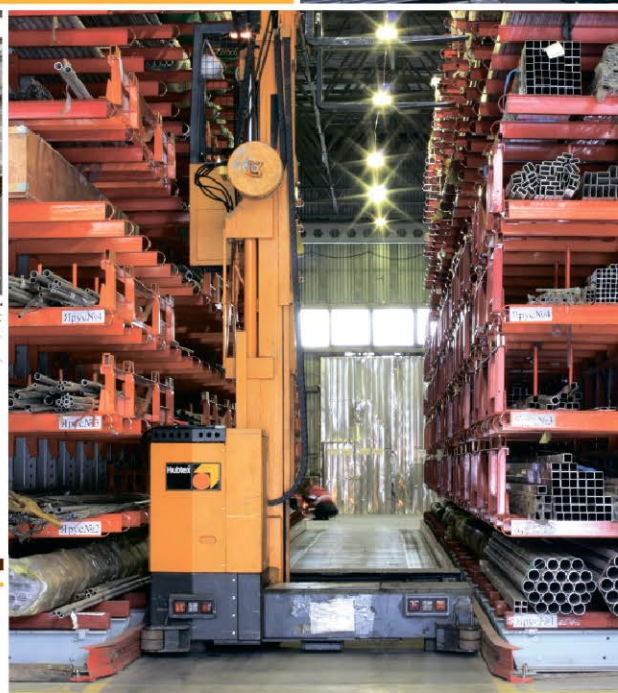

10000

ТОНН

НЕСНИЖАЕМЫЙ
СКЛАДСКОЙ ОСТАТОК

Щелково, +7 (495) 775-55-22
ул. Заводская, д. 14Б, пом.17

Челябинск, +7 (351) 242-01-02
пр-т Победы, д. 158, офис 407

Санкт-Петербург, +7 (812) 454-21-54
пр-т Обуховской обороны, д. 112, литера И, БЦ "ВАНТ", офис 235

Воронеж, +7 (473) 300-38-88
ул. Солнечная, 10Б, БК "Крепезж", офис 210

Краснодар, +7 (861) 205-00-10
Ростовское шоссе, д. 14/2, офис 306

Самара, +7 (846) 300-44-54
Заводское шоссе, д. 111, офис 452

Нижний Новгород, +7 (831) 260-12-22
ул. Варварская, д. 32, литера Д, офис 301

Пятигорск, +7 (8793) 31-78-22
Черкесское шоссе, д. 11



BRITISH STANDARD**BS EN
10219-2:2006**

Cold formed welded structural hollow sections of non-alloy and fine grain steels —

Part 2: Tolerances, dimensions and sectional properties

The European Standard EN 10219-2:2006 has the status of a
British Standard

ICS 77.140.75

National foreword

This British Standard is the official English language version of EN 10219-2:2006. It supersedes BS EN 10219-2:1997 which is withdrawn.

The UK participation in its preparation was entrusted to Technical Committee ISE/12, Structural steel, which has the responsibility to:

- aid enquirers to understand the text;
- present to the responsible international/European committee any enquiries on the interpretation, or proposals for change, and keep UK interests informed;
- monitor related international and European developments and promulgate them in the UK.

A list of organizations represented on this committee can be obtained on request to its secretary.

Cross-references

The British Standards which implement international or European publications referred to in this document may be found in the *BSI Catalogue* under the section entitled "International Standards Correspondence Index", or by using the "Search" facility of the *BSI Electronic Catalogue* or of British Standards Online.

This publication does not purport to include all the necessary provisions of a contract. Users are responsible for its correct application.

Compliance with a British Standard does not of itself confer immunity from legal obligations.

Summary of pages

This document comprises a front cover, an inside front cover, the EN title page, pages 2 to 36, an inside back cover and a back cover.

The BSI copyright notice displayed in this document indicates when the document was last issued.

Amendments issued since publication

Amd. No.	Date	Comments

This British Standard was published under the authority of the Standards Policy and Strategy Committee on 31 May 2006

© BSI 2006

ISBN 0 580 48464 5

EUROPEAN STANDARD
NORME EUROPÉENNE
EUROPÄISCHE NORM

EN 10219-2

April 2006

ICS 77.140.75

Supersedes EN 10219-2:1997

English Version

Cold formed welded structural hollow sections of non-alloy and
fine grain steels - Part 2: Tolerances, dimensions and sectional
properties

Profils creux pour la construction soudés, formés à froid en
aciers non alliés et à grains fins - Partie 2 : Tolérances,
dimensions et caractéristiques de profil

Kaltgefertigte geschweißte Hohlprofile für den Stahlbau aus
unlegierten Baustählen und aus Feinkornbaustählen - Teil
2: Grenzabmaße, Maße und statische Werte

This European Standard was approved by CEN on 18 March 2006.

CEN members are bound to comply with the CEN/CENELEC Internal Regulations which stipulate the conditions for giving this European Standard the status of a national standard without any alteration. Up-to-date lists and bibliographical references concerning such national standards may be obtained on application to the Central Secretariat or to any CEN member.

This European Standard exists in three official versions (English, French, German). A version in any other language made by translation under the responsibility of a CEN member into its own language and notified to the Central Secretariat has the same status as the official versions.

CEN members are the national standards bodies of Austria, Belgium, Cyprus, Czech Republic, Denmark, Estonia, Finland, France, Germany, Greece, Hungary, Iceland, Ireland, Italy, Latvia, Lithuania, Luxembourg, Malta, Netherlands, Norway, Poland, Portugal, Romania, Slovakia, Slovenia, Spain, Sweden, Switzerland and United Kingdom.



EUROPEAN COMMITTEE FOR STANDARDIZATION
COMITÉ EUROPÉEN DE NORMALISATION
EUROPÄISCHES KOMITEE FÜR NORMUNG

Management Centre: rue de Stassart, 36 B-1050 Brussels

EN 10219-2:2006 (E)

Contents

Foreword	3
1 Scope	4
2 Normative references	4
3 Terms and definitions	4
4 Symbols	4
5 Information to be obtained by the manufacturer	5
6 Tolerances	5
7 Measurement of size and shape	8
7.1 General	8
7.2 Outside dimensions	8
7.3 Thickness	8
7.4 Out-of-roundness	9
7.5 Concavity and convexity	9
7.6 Squareness of sides	10
7.7 External corner profile	11
7.8 Twist	11
7.9 Straightness	12
8 Dimensions and sectional properties	12
Annex A (informative) Additional tolerances for piling tube	14
A.1 General	14
A.2 Out of roundness tolerance	14
A.3 Accidental eccentricity tolerance	15
A.4 Dimple tolerance	17
Annex B (normative) Formulae for the calculation of sectional properties	20
B.1 General	20
B.2 Circular hollow sections	20
B.3 Rectangular, or square, hollow sections	21
Annex C (normative) Sectional properties for a limited range of standard sizes	24
Bibliography	36

EN 10219-2:2006 (E)

Foreword

This European Standard (EN 10219-2:2006) has been prepared by Technical Committee ECISS/TC 10 "Structural steels - Grades and qualities", the secretariat of which is held by NEN.

This European Standard shall be given the status of a national standard, either by publication of an identical text or by endorsement, at the latest by October 2006, and conflicting national standards shall be withdrawn at the latest by October 2006.

This European Standard supersedes EN 10219—2:1997.

This standard consists of the following parts under the general title 'Cold formed welded structural hollow sections of non-alloy and fine grain steels':

- Part 1: Technical delivery conditions
- Part 2: Tolerances, dimensions and sectional properties

It forms part of a series of standards on hollow sections together with EN 10210-1 and 2, which are also under revision.

According to the CEN/CENELEC Internal Regulations, the national standards organizations of the following countries are bound to implement this European Standard: Austria, Belgium, Cyprus, Czech Republic, Denmark, Estonia, Finland, France, Germany, Greece, Hungary, Iceland, Ireland, Italy, Latvia, Lithuania, Luxembourg, Malta, Netherlands, Norway, Poland, Portugal, Romania, Slovakia, Slovenia, Spain, Sweden, Switzerland and United Kingdom.

EN 10219-2:2006 (E)

1 Scope

This part of EN 10219 specifies tolerances for cold formed welded circular, square and rectangular structural hollow sections, manufactured in wall thicknesses up to 40 mm, in the following size ranges:

Circular: Outside diameters up to 2 500 mm

Square: Outside dimensions up to 500 mm x 500 mm

Rectangular: Outside dimensions up to 500 mm x 300 mm

The formulae for calculating sectional properties of sections manufactured to the dimensional tolerances of this standard, to be used for the purposes of structural design, are given in Annex B.

Dimensions and sectional properties for a limited range of sizes are given in Annex C.

Technical delivery conditions are specified in EN 10219-1.

NOTE The designation of the sections' major axis (yy) and its minor axis (zz) align with the axis designation used for structural design in the structural Eurocodes.

2 Normative references

The following referenced documents are indispensable for the application of this European Standard. For dated references, only the edition cited applies. For undated references, the latest edition of the referenced document (including any amendments) applies.

EN 10219-1:2006, *Cold formed welded structural hollow sections of non-alloy and fine grain steels — Part 1: Technical delivery conditions*

3 Terms and definitions

For the purposes of this European Standard, the terms and definitions given in EN 10219-1:2006 apply.

4 Symbols

For the purposes of this European Standard, the symbols defined in Table 1 apply.

EN 10219-2:2006 (E)

Table 1 — Symbols and definitions

Symbol	Unit	Definition
A	cm ²	Cross-sectional area
A_s	m ² /m	Superficial area per metre length
B	mm	Specified side dimension of a square hollow section. Specified dimension of the shorter side of a rectangular hollow section
C_1/C_2	mm	Length of corner region of a square or rectangular hollow section
C_t	cm ³	Torsional modulus constant
D	mm	Specified outside diameter of a circular hollow section
D_{max}/D_{min}	mm	The maximum and minimum outside diameter of a circular hollow section measured in the same plane
e	mm	Deviation from straightness
H	mm	Specified dimension of the longer side of a rectangular hollow section
I	cm ⁴	Second moment of area
I_t	cm ⁴	Torsional inertia constant (polar moment of inertia in the case of circular hollow sections only)
i	cm	Radius of gyration
L	mm	Length
M	kg/m	Mass per unit length
O	%	Out-of-roundness
R	mm	External corner radius of a square or rectangular hollow section
T	mm	Specified thickness
V	mm	Total measured twist
V_1	mm	Twist measured at one end of a section
W_e	cm ³	Elastic section modulus
W_{pl}	cm ³	Plastic section modulus
x_1	mm	Concavity of a side of a square or rectangular hollow section
x_2	mm	Convexity of a side of a square or rectangular hollow section
yy'	—	Axis of cross-section, major axis of a rectangular hollow section
zz	—	Axis of cross-section, minor axis of a rectangular hollow section
θ	°	Angle between adjacent sides of a square or rectangular hollow section

5 Information to be obtained by the manufacturer

The following mandatory information from this part of EN 10219 shall be obtained by the manufacturer at the time of enquiry and order.

- The type of length, length range or length (see Table 4).
- The dimensions (see Clause B).

NOTE This information is included in the list of information to be obtained by the manufacturer contained in EN 10219-1.

6 Tolerances

6.1 Tolerances shall not exceed the values given in Table 2 for shape and mass, Table 3 for external corner profiles, Table 4 for manufacturer's delivered length and Table 5 for the height of the internal and external weld bead of submerged arc welded hollow sections.

6.2 The internal corners of square and rectangular hollow sections shall be rounded.

NOTE The internal corner profile is not specified.

EN 10219-2:2006 (E)

6.3 Additional tolerances for out-of-roundness, accidental eccentricity and dimples may be applied to tubes of diameter ≥ 900 mm and $D/T \geq 50$ when they are to be used as bearing piles or primary elements in combined walls in accordance with ENV 1993-5. In order for these additional tolerances to be applied the fabrication tolerance quality class, A, B, or C should be agreed. See Annex A.

Table 2 — Tolerances on shape and mass

Characteristic	Circular hollow sections	Square and rectangular hollow sections	
		Side length mm	Tolerance
Outside dimensions (D , B and H)	$\pm 1\%$ with a minimum of $\pm 0,5$ mm and a maximum of $\pm 1,0$ mm	$H, B < 100$	$\pm 1\%$ with a minimum of $\pm 0,5$ mm
		$100 \leq H, B \leq 200$	$\pm 0,8\%$
		$H, B > 200$	$\pm 0,6\%$
Thickness (T)	For $D \leq 406,4$ mm: $T \leq 5$ mm $\pm 10\%$ $T > 5$ mm $\pm 0,5$ mm	$T \leq 5$ mm $\pm 10\%$ $T > 5$ mm $\pm 0,5$ mm	
	For $D > 406,4$ mm: $\pm 10\%$ with a maximum of ± 2 mm		
Out-of-roundness (U)	2 % for hollow sections having a diameter to thickness ratio not exceeding 100 ^a	—	
Concavity/convexity (x_1, x_2) ^b	—	Max. 0,8 % with a minimum of 0,5 mm	
Squareness of side (θ)	—	$90^\circ \pm 1^\circ$	
External corner profile (C_1, C_2 or R)	—	See Table 3	
Twist (V)	—	2 mm plus 0,5 mm/m length	
Straightness (e)	0,20 % of total length and 3 mm over any 1 m length	0,15 % of total length and 3 mm over any 1 m length	
Mass per unit length (M)	$\pm 6\%$ on individual delivered lengths		
<p>^a Where the diameter to thickness ratio exceeds 100 the tolerance on out-of-roundness shall be agreed.</p> <p>^b The tolerance on convexity and concavity is independent of the tolerance on outside dimensions</p>			

EN 10219-2:2006 (E)

Table 3 — Tolerances on external corner profiles

Dimensions in millimetres

Thickness T	External corner profile C_1 , C_2 or R^a
$T \leq 6$	$1,6T$ to $2,4T$
$6 < T \leq 10$	$2,0T$ to $3,0T$
$10 < T$	$2,4T$ to $3,6T$

^a The sides need not be tangential to the corner arcs.

Table 4 — Tolerances on manufacturer's delivered length

Dimensions in millimetres

Type of length ^a	Range of length or length L	Tolerance
Random length	$4\ 000 < L \leq 16\ 000$ with a range of 2 000 per order item	10 % of sections supplied may be below the minimum for the ordered range but not shorter than 75 % of the minimum range length
Approximate length	$\geq 4\ 000$	$^{+50}_0$ mm
Exact length ^b	$< 6\ 000$	$^{-5}_0$ mm
	$6\ 000 \leq L \leq 10\ 000$	$^{-15}_0$ mm
	$> 10\ 000$	$^{+5}_0$ mm +1 mm/m

^a The manufacturer shall establish at the time of enquiry and order the type of length required and the length range or length.

^b Common lengths available are 6 m and 12 m.

EN 10219-2:2006 (E)

Table 5 — Tolerance on height of internal and external weld bead for submerged arc welded hollow sections

Dimensions in millimetres

Thickness, t	Maximum weld bead height
$\leq 14,2$	3,5
$> 14,2$	4,8

7 Measurement of size and shape

7.1 General

All external dimensions, including out-of-roundness, shall be measured at a distance from the end of the hollow section of not less than D for circular sections, B for square sections or H for rectangular sections, with a minimum of 100 mm.

7.2 Outside dimensions

For circular hollow sections the diameter (D) shall be measured either directly, e.g. using a calliper gauge, or by circumference tape at the discretion of the manufacturer.

The limiting cross-sectional positions for measuring B and H for square and rectangular hollow sections are shown in Figure 1.

7.3 Thickness

The thickness (t) shall be measured at a position not less than $2t$ from the weld.

The limiting cross-sectional positions for measuring the thickness of square and rectangular hollow sections are shown in Figure 1.

NOTE Thickness is normally measured within a distance of half the outside diameter or half the dimension of the longer side from the end of the section.

EN 10219-2:2006 (E)

Dimensions in millimetres

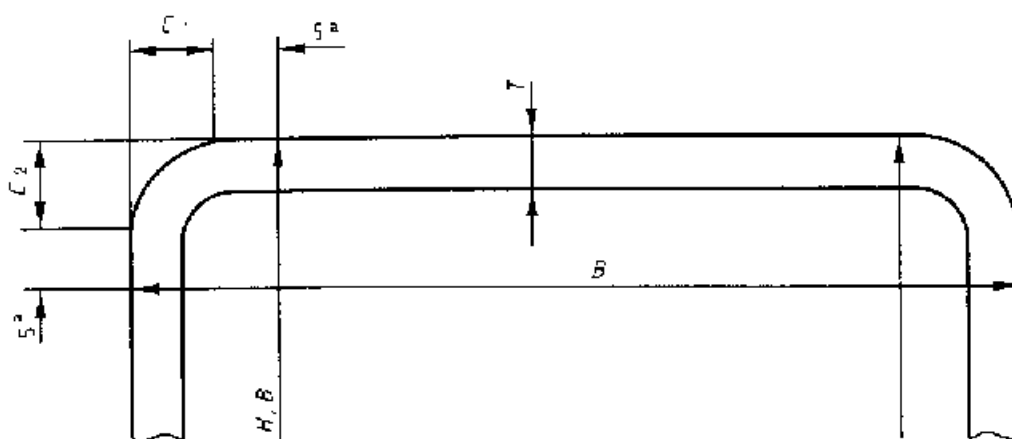

^a This dimension is a maximum when measuring B or H and a minimum when measuring T .

Figure 1 — Limiting cross-sectional positions for measuring the dimensions B , H and T for square or rectangular hollow sections

7.4 Out-of-roundness

The out-of-roundness (O) of a circular hollow section shall be calculated from the following equation, but see Annex A for piling tube.

$$O(\%) = \frac{D_{\max} - D_{\min}}{D} \times 100$$

7.5 Concavity and convexity

The concavity (x_1) or the convexity (x_2) of the sides of a square or rectangular hollow section shall be measured as shown in Figure 2.

The percentage concavity or convexity shall be calculated as follows:

$$\frac{x_1}{B} \times 100\%; \frac{x_2}{B} \times 100\%; \frac{x_1}{H} \times 100\%; \frac{x_2}{H} \times 100\%$$

where B and H are the dimensions of the sides containing the concavity x_1 or the convexity x_2 .

EN 10219-2:2006 (E)

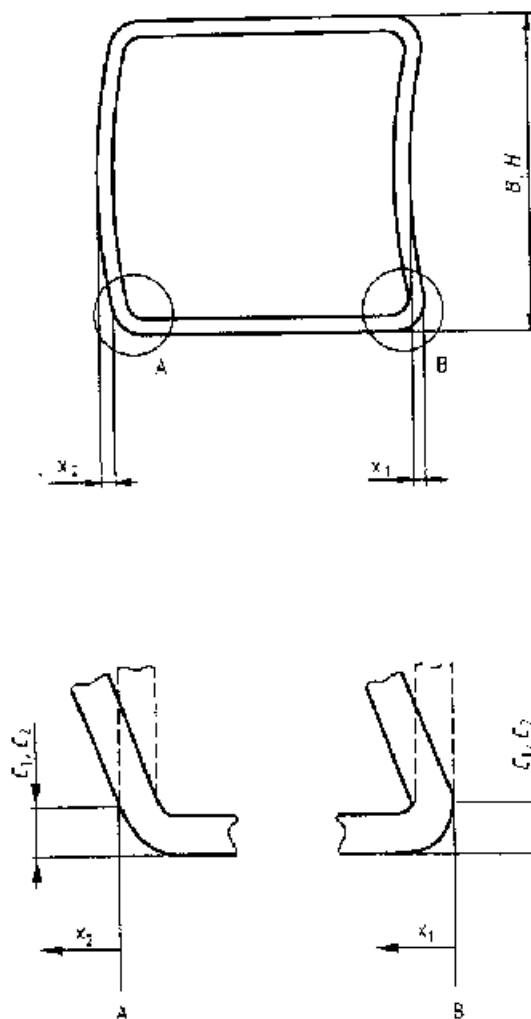

Figure 2 — Measurement of concavity/convexity of square or rectangular hollow sections

7.6 Squareness of sides

The deviation from squareness of the sides of a square or rectangular hollow section shall be measured as the difference between 90° and θ as shown in Figure 3.

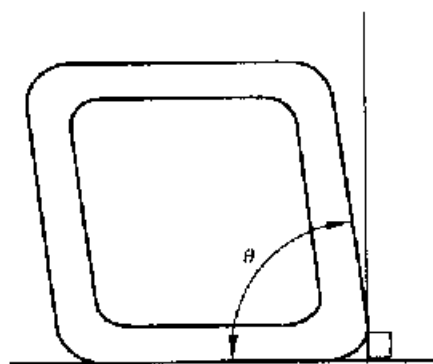

Figure 3 — Squareness of sides of square or rectangular hollow sections

7.7 External corner profile

7.7.1 The external corner profile of a square or rectangular hollow section shall be measured according to 7.7.2 or 7.7.3 at the discretion of the manufacturer.

7.7.2 The corner arc shall be measured with a radius gauge.

7.7.3 The distance between the intersection of the flat side and the corner arc and the intersection of the projections of the flat sides to the corner (C_1 and C_2 in Figure 4) shall be measured.

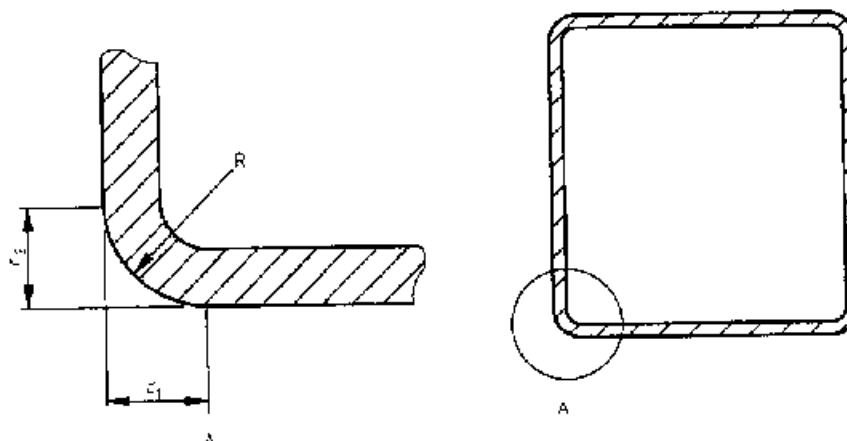

Figure 4 — Outside corner profile of square or rectangular hollow sections

7.8 Twist

7.8.1 The twist (T) in a square or rectangular hollow section shall be determined in accordance with 7.8.2 or 7.8.3 at the discretion of the manufacturer.

7.8.2 The hollow section shall be placed on a horizontal surface with one side at one end pressed flat against the surface. At the opposite end of the hollow section the difference in height of the two lower corners from the horizontal surface (see Figure 5) shall be determined.

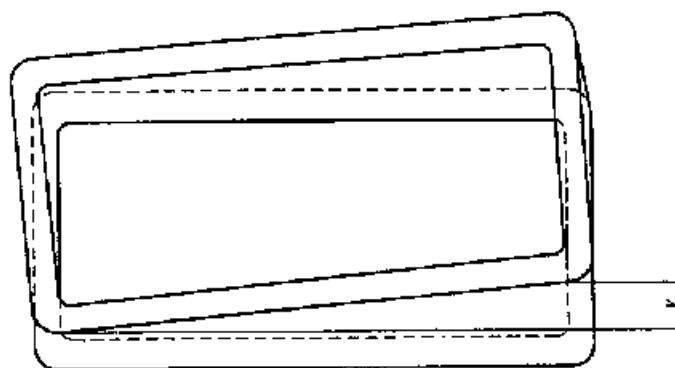
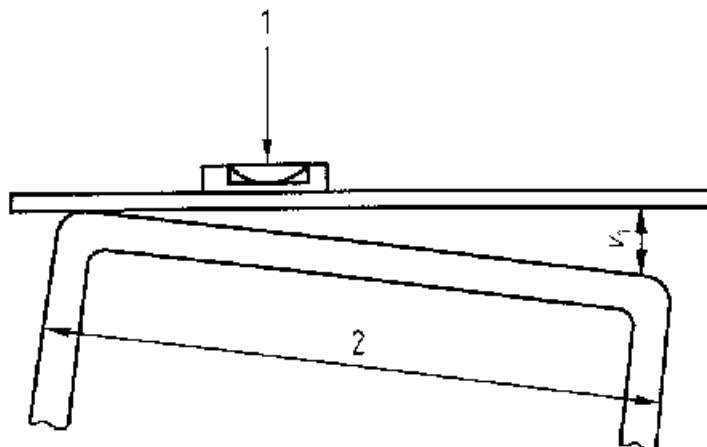

Figure 5 — Twist of square or rectangular hollow sections

7.8.3 The twist shall be measured with a spirit level and micrometer gauge (screw). The reference length of the spirit level shall be the distance between the intersection of the flat sides and the corner arcs (see Figure 6). The twist T is the difference between the values T_1 (see Figure 6) measured at each end of the hollow section.

EN 10219-2:2006 (E)

**Key**

- 1 Spirit level
2 H for rectangular sections, B for square sections

Figure 6 — Measurement of twist

7.9 Straightness

The deviation from straightness (e) of the total length of a hollow section shall be measured at the point of maximum departure of the hollow section from a straight line connecting its two ends, as shown in Figure 7 where L is the manufacturer's delivered length. The percentage deviation from straightness shall be calculated as follows:

$$\frac{e}{L} \times 100\%$$

In addition the local deviation (e) from straightness of a hollow section, measured at any point along its length from a straight line length L of 1 m, shall be not more than 3 mm.

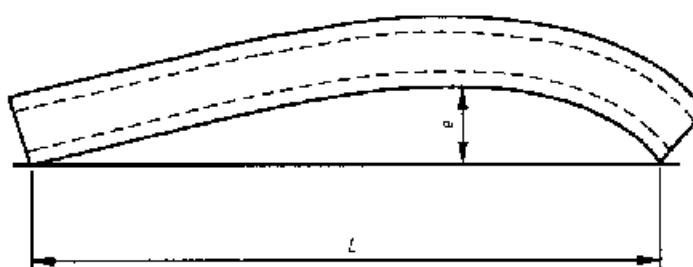

Figure 7 — Measurement of deviation from straightness

8 Dimensions and sectional properties

The nominal sectional properties of hollow sections within the scope of this part of EN 10219 and manufactured to the dimensional tolerances of this standard, required for the purposes of structural design, shall be calculated in accordance with Annex B.

The sectional properties for a limited range of standard sizes of cold formed hollow sections are given in Table C.1 for circular sections, Table C.2 for square sections and Table C.3 for rectangular sections. These sectional properties were calculated from the formulae given in Annex B.

EN 10219-2:2006 (E)

NOTE Not all sizes and thicknesses shown in Tables C.1, C.2 and C.3 are available from all manufacturers and the user is recommended to check availability. Other sizes and thicknesses within the scope of this standard may be available.

EN 10219-2:2006 (E)

Annex A (informative)

Additional tolerances for piling tube

A.1 General

This annex contains guidance on additional tolerances that can be applied to tubes when they are to be used as bearing piles or primary elements in combined walls in accordance with ENV 1993-5. These requirements are generally relevant to tubes of diameter ≥ 900 mm and $D/T \geq 100$.

For verification of tubular piles subject to shell buckling, ENV 1993-5: Piling refers to ENV 1993-1-6. Shell buckling is partly governed by geometrical imperfections of the shell due to out-of-roundness, accidental eccentricity and dimples. ENV 1993-1-6 specifies limits for each of these geometrical imperfections, based on the concept of fabrication quality classes. Details of how to assess out-of-roundness, accidental eccentricity and dimples, and the recommended maximum permitted values for each fabrication quality class, are given in A.2, A.3 and A.4.

NOTE 1 See ENV 1993-1-6 for further details of fabrication tolerance quality classes, their design implications and for definitions and use of symbols.

NOTE 2 The values of certain parameters, given in Tables A.1, A.2 and A.3 may be subject to change by national application of ENV 1993-1-6. Nationally determined parameters will be given in the relevant National Annex of ENV 1993-1-6.

A.2 Out of roundness tolerance

Out-of-roundness of a tubular pile is assessed in terms of the parameter U ; the difference between the maximum and minimum values of the measured internal diameter, relative to the nominal inside diameter, see Figure A.1, given by:

$$U = \frac{d_{\max} - d_{\min}}{d_{\text{nom}}}$$

Where:

- d_{\max} is the maximum measured internal diameter;
- d_{\min} is the minimum measured internal diameter;
- d_{nom} is the nominal inside diameter ($d = D - 2T$, see B.2).

An appropriate number of diameters should be measured in order to identify the maximum and minimum values.

EN 10219-2:2006 (E)

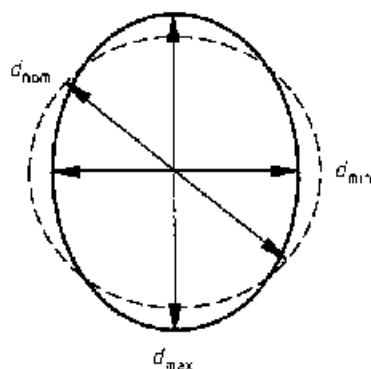
Figure A.1 — Assessment of d_{min} and d_{max} and relationship to d

The out-of-roundness parameter U_r should satisfy the condition:

$$U_r \leq U_{r, max}$$

where:

$U_{r, max}$ is the maximum permitted value for the out-of-roundness parameter.

Recommended values for each fabrication tolerance quality class are given in Table A.1.

Table A.1 — Maximum permitted values for out-of-roundness parameter $U_{r, max}$

Dimensions in mm

Fabrication tolerance quality class	Description	Diameter range		
		$d \leq 500$	$500 < d < 1250$	$1250 \leq d$
		Value of $U_{r, max}$ ^a		
Class A	Excellent	0,14	$0,007 + 0,0093 (1,25 - d)$	0,007
Class B	High	0,02	$0,010 + 0,0133 (1,25 - d)$	0,01
Class C	Normal	0,03	$0,015 + 0,020 (1,25 - d)$	0,015

^a The values of this parameter may be subject to change by national application of ENV 1993-1-6. If in doubt, reference should be made to the relevant National Annex of ENV 1993-1-6.

A.3 Accidental eccentricity tolerance

Accidental eccentricity, the unintentional eccentricity due to misalignment of the tube walls at horizontal joints, is assessed in terms of the parameter U_e given by:

$$U_e = \frac{e_R}{T}$$

EN 10219-2:2006 (E)

where:

- e_a is the accidental eccentricity between the mid points of the tube walls at the joint, compared to their normal thickness;
- T is the tube wall thickness.

NOTE For joints involving tubes of different thicknesses, it is recommended to refer to ENV 1993-1-8.

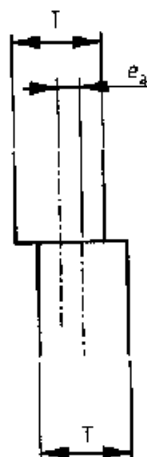

Figure A.2 — Measurement of tube wall eccentricity (e_a)

The accidental eccentricity e_a should satisfy the condition:

$$e_a \leq e_{a, \max}$$

where:

$e_{a, \max}$ is the maximum permitted accidental eccentricity.

Recommended values for each fabrication tolerance quality class are given in Table A.2.

The accidental eccentricity parameter U_e should satisfy the condition:

$$U_e \leq U_{e, \max}$$

where:

$U_{e, \max}$ is the maximum permitted value for the accidental eccentricity parameter.

Recommended values for each fabrication tolerance quality class are given in Table A.2.

Table A.2 — Maximum permitted values for accidental eccentricity parameter $U_{e, \max}$ and for accidental eccentricity $e_{a, \max}$

Dimensions in mm

Fabrication tolerance quality class	Description	$U_{e, \max}^a$	$e_{a, \max}^a$
Class A	Excellent	0,14	2
Class B	High	0,2	3
Class C	Normal	0,3	4

^a The values of these parameters may be subject to change by national application of ENV 1993-1-6. If in doubt, reference should be made to the relevant National Annex of ENV 1993-1-6.

A.4 Dimple tolerance

The depth of initial dimples in the tube wall w_0 is measured, in both the meridional and circumferential directions, using a measurement gauge, see Figure A.3, of length l_g where:

- meridionally and circumferentially $l_g = 4\sqrt{rT}$
- across welds $l_g = 25 T$ but $l_g \leq 500$ mm

The gauge used for meridional measurements should be straight but that used for measurements in the circumferential direction should have a radius of curvature r where:

$$r = \frac{(D \cdot T)}{2}$$

NOTE For joints involving tubes of different thicknesses, it is recommended to refer to ENV 1993-1-6.

EN 10219-2:2006 (E)

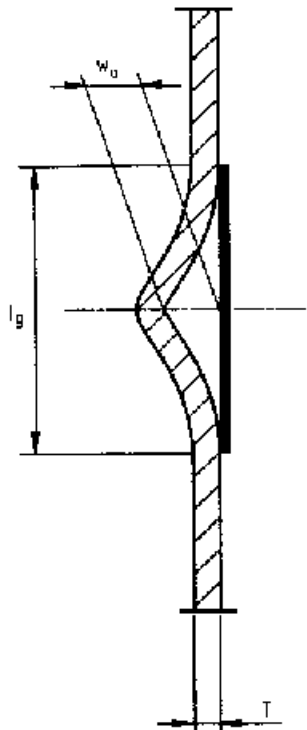
Figure A.3 — Measurement of depth w_d of initial dimples

The level of initial dimples in the wall of the tubular pile is assessed in terms of the dimple tolerance parameter U_d given by:

$$U_d = \frac{w_d}{l_g}$$

The dimple tolerance parameter U_d should satisfy the condition:

$$U_d \leq U_{d, \max}$$

where:

$U_{d, \max}$ is the maximum permitted value for the dimple tolerance parameter.

Recommended values for each fabrication tolerance class are given in Table A.3.

EN 10219-2:2006 (E)

Table A.3 — Maximum permitted values for dimple tolerance parameter $U_{d, \max}$
Dimensions in mm

Fabrication tolerance quality class	Description	$U_{d, \max}$
Class A	Excellent	0,006
Class B	High	0,01
Class C	Normal	0,016

* The values of this parameter may be subject to change by national application of ENV 1993-1-6. If in doubt, reference should be made to the National Annex of ENV 1993-1-6.

EN 10219-2:2006 (E)

Annex B (normative)

Formulae for the calculation of sectional properties

B.1 General

Tables C.1, C.2 and C.3 of this standard give nominal sectional properties for a limited range of sizes of cold formed hollow sections. The nominal sectional properties of hollow sections supplied to the requirements of this standard shall be calculated using the formulae given below.

NOTE The designation of the sections' major axis (yy) and its minor axis (zz) align with the axis designation used for structural design in the structural Eurocodes. This is a change from previous axis designations.

B.2 Circular hollow sections

The sectional properties for circular hollow sections in Table C.1 are calculated using the formulae given below.

Specified outside diameter	(D)	(mm)
Specified thickness	(T)	(mm)
Inside diameter	$(d = D - 2T)$	(mm)

These parameters, which characterize the shape of circular hollow sections, may vary within the tolerances allowed by this standard and the sectional properties still remain valid.

Superficial area per metre length	$A_s = \frac{\pi D}{10^3}$	(m ² /m)
Cross-sectional area	$A = \frac{\pi(D^2 - d^2)}{4 \times 10^2}$	(cm ²)
Mass per unit length	$M = 0,785 \times A$	(kg/m)
Second moment of area	$I = \frac{\pi(D^4 - d^4)}{64 \times 10^4}$	(cm ⁴)
Radius of gyration	$i = \sqrt{\frac{I}{A}}$	(cm)

EN 10219-2:2006 (E)

Elastic section modulus	$W_{el} = \frac{2I \times 10}{D}$	(cm ³)
Plastic section modulus	$W_{pl} = \frac{D^3 - d^3}{6 \times 10^3}$	(cm ³)
Torsional inertia constant (polar moment of inertia)	$I_p = 2I$	(cm ⁴)
Torsional modulus constant	$C_T = 2W_{pl}$	(cm ³)

B.3 Rectangular, or square, hollow sections

The sectional properties for square hollow sections in Table C.2 and for rectangular hollow sections in Table C.3 are calculated using the formulae given below.

Specified side dimension of a square hollow section or shorter side of a rectangular hollow section (B) (mm)

Specified dimension of the longer side of a rectangular hollow section (H) (mm)

Specified thickness (T) (mm)

External corner radius (r_o) for calculation is:

for thicknesses ≤ 6 mm 2,0 T (mm)

for thicknesses > 6 mm ≤ 10 mm 2,5 T (mm)

for thicknesses > 10 mm 3,0 T (mm)

Internal corner radius (r_i) for calculation is:

for thicknesses ≤ 6 mm 1,0 T (mm)

for thicknesses > 6 mm and ≤ 10 mm 1,5 T (mm)

for thicknesses > 10 mm 2,0 T (mm)

These parameters, which characterize the geometric shape of rectangular, or square, hollow sections, may vary within the tolerances allowed by this standard and the sectional properties still remain valid.

Superficial area per metre length $A_s = \frac{2}{10^3} (H + B - 4r_o + \pi r_o)$ (m²/m)

EN 10219-2:2006 (E)

Cross-sectional area $A = \frac{2T(B+H-2T) - (4-\pi)(r_o^2 - r_i^2)}{10^2}$ (cm²)

Mass per unit length $M = 0.785 \cdot A$ (kg/m)

Second moment of area

Major axis $I_{yy} = \frac{1}{10^4} \left[\frac{BH^3}{12} - \frac{(B-2T)(H-2T)^3}{12} - 4(I_g + A_g h_g^2) + 4(I_{gg} - A_g h_g^2) \right]$ (cm⁴)

Minor axis $I_{zz} = \frac{1}{10^4} \left[\frac{HB^3}{12} - \frac{(H-2T)(B-2T)^3}{12} - 4(I_g + A_g h_g^2) + 4(I_{gg} + A_g h_g^2) \right]$ (cm⁴)

Radius of gyration

Major axis $i_{yy} = \sqrt{\frac{I_{yy}}{A}}$ (cm)

Minor axis $i_{zz} = \sqrt{\frac{I_{zz}}{A}}$ (cm)

Elastic section modulus

Major axis $W_{el yy} = \frac{2I_{yy}}{H} \times 10$ (cm³)

Minor axis $W_{el zz} = \frac{2I_{zz}}{B} \times 10$ (cm³)

Plastic section modulus

Major axis $W_{pl yy} = \frac{1}{10^3} \left[\frac{BH^2}{4} - \frac{(B-2T)(H-2T)^2}{4} - 4(A_g h_g) + 4(A_g h_g) \right]$ (cm³)

Minor axis $W_{pl zz} = \frac{1}{10^3} \left[\frac{HB^2}{4} - \frac{(H-2T)(B-2T)^2}{4} - 4(A_g h_g) + 4(A_g h_g) \right]$ (cm³)

EN 10219-2:2006 (E)

Torsional inertia constant

$$I_t = \frac{1}{10^4} \left[I^{1/3} \frac{h}{3} + 2KA_s \right] \quad (\text{cm}^4)$$

Torsional modulus constant

$$C_t = 10 \left[\frac{I_t}{T + K/T} \right] \quad (\text{cm}^3)$$

Where

$$A_s = \left(1 - \frac{\pi}{4} \right) r_o^2 \quad (\text{mm}^2)$$

$$A_i = \left(1 - \frac{\pi}{4} \right) r_i^2 \quad (\text{mm}^2)$$

Major axis

$$h_o = \frac{H}{2} - \left(\frac{10 - 3\pi}{12 - 3\pi} \right) r_o \quad (\text{mm})$$

(For minor axis substitute B for H .)

Major axis

$$h_s = \frac{H - 2T}{2} - \left(\frac{10 - 3\pi}{12 - 3\pi} \right) r_i \quad (\text{mm})$$

(For minor axis substitute B for H .)

$$I_o = \left(\frac{1}{3} - \frac{\pi}{16} - \frac{1}{3(12 - 3\pi)} \right) r_o^4 \quad (\text{mm}^4)$$

$$I_i = \left(\frac{1}{3} - \frac{\pi}{16} - \frac{1}{3(12 - 3\pi)} \right) r_i^4 \quad (\text{mm}^4)$$

$$h = 2[(B - T) + (H - T)] - 2R_c(4 - \pi) \quad (\text{mm})$$

$$A_o = (B - T)(H - T) - R_c^2(4 - \pi) \quad (\text{mm})$$

$$K = \frac{2A_o T}{h} \quad (\text{mm}^2)$$

$$R_c = \frac{r_o - r_i}{2} \quad (\text{mm})$$

EN 10219-2:2006 (E)

Annex C (normative)

Sectional properties for a limited range of standard sizes

Table C.1 — Nominal dimensions and sectional properties of a limited range of circular hollow sections (see Figure C.1)

Specified outside diameter	Specified thickness	Mass per unit length	Cross-sectional area	Second moment of area	Radius of gyration	Elastic section modulus	Plastic section modulus	Torsional inertia constant	Torsional modulus constant	Superficial area per metre length	Nominal length per tonne
D mm	T mm	M kg/m	A cm ²	I cm ⁴	r cm	W_x cm ³	W_p cm ³	I_t cm ⁴	C_t cm ²	A_s m ² /m	L m
21,3	2,0	0,95	1,21	0,571	0,686	0,538	0,748	1,14	1,07	0,067	1050
21,3	2,5	1,16	1,48	0,564	0,671	0,623	0,889	1,33	1,25	0,067	863
21,3	3,0	1,35	1,72	0,741	0,666	0,696	1,01	1,48	1,39	0,067	739
26,9	2,0	1,23	1,56	1,22	0,883	0,907	1,24	2,44	1,81	0,085	814
26,9	2,5	1,50	1,92	1,44	0,867	1,07	1,49	2,86	2,14	0,085	665
26,9	3,0	1,77	2,25	1,63	0,852	1,21	1,72	3,27	2,43	0,085	566
33,7	2,0	1,58	1,99	2,51	1,12	1,49	2,01	5,02	2,98	0,106	640
33,7	2,5	1,92	2,45	3,00	1,11	1,78	2,44	6,00	3,66	0,106	520
33,7	3,0	2,27	2,89	3,44	1,09	2,04	2,84	6,88	4,08	0,106	440
42,4	2,0	1,99	2,54	5,19	1,43	2,45	3,27	10,4	4,90	0,133	502
42,4	2,5	2,46	3,13	5,26	1,41	2,95	3,99	12,5	5,91	0,133	407
42,4	3,0	2,91	3,71	7,25	1,40	3,42	4,67	14,5	6,84	0,133	343
42,4	4,0	3,79	4,83	8,99	1,36	4,24	5,92	18,0	8,48	0,133	284
48,3	2,0	2,28	2,91	7,91	1,64	3,23	4,29	15,6	6,47	0,152	438
48,3	2,5	2,82	3,60	9,46	1,62	3,92	5,25	18,9	7,83	0,152	354
48,3	3,0	3,35	4,27	11,0	1,61	4,55	6,17	22,0	9,11	0,152	298
48,3	4,0	4,37	5,57	13,8	1,57	5,70	7,87	27,5	11,4	0,152	229
48,3	5,0	5,34	6,80	16,2	1,54	6,69	9,42	32,3	13,4	0,152	187
60,3	2,0	2,88	3,66	15,6	2,06	5,17	8,80	31,2	10,3	0,189	348
60,3	2,5	3,56	4,54	19,0	2,05	6,30	8,36	38,0	12,6	0,189	281
60,3	3,0	4,24	5,40	22,2	2,03	7,37	9,85	44,4	14,7	0,189	236
60,3	4,0	5,55	7,07	28,2	2,00	9,34	12,7	56,3	18,7	0,189	180
60,3	5,0	6,82	8,69	33,5	1,96	11,1	16,3	67,0	22,2	0,189	147
76,1	2,0	3,65	4,66	32,0	2,62	8,40	11,0	64,0	16,9	0,239	274
76,1	2,5	4,54	5,78	39,2	2,60	10,3	13,5	78,4	20,6	0,239	220
76,1	3,0	5,41	6,89	46,1	2,59	12,1	16,0	92,2	24,2	0,239	185
76,1	4,0	7,11	9,06	59,1	2,56	15,5	20,8	118	31,0	0,239	141
76,1	5,0	8,77	11,2	70,9	2,52	18,6	25,3	142	37,3	0,239	114
76,1	6,0	10,4	13,2	81,8	2,49	21,5	29,8	164	43,0	0,239	96,4
76,1	6,3	10,9	13,8	84,8	2,48	22,3	30,8	170	44,6	0,239	92,2
88,9	2,0	4,29	5,46	51,6	3,07	11,6	15,1	103	23,2	0,279	233
88,9	2,5	5,33	6,79	63,4	3,06	14,3	18,7	127	28,5	0,279	188
88,9	3,0	6,36	8,10	74,9	3,04	16,8	22,1	150	33,6	0,279	157
88,9	4,0	8,38	10,7	96,3	3,00	21,7	28,9	193	43,3	0,279	119
88,9	5,0	10,3	13,2	116	2,97	26,2	35,2	233	52,4	0,279	96,7
88,9	6,0	12,3	15,8	135	2,94	30,4	41,3	270	60,7	0,279	81,6
88,9	6,3	12,8	16,3	140	2,93	31,5	43,1	280	63,1	0,279	77,9
101,6	2,0	4,91	6,26	77,8	3,52	15,3	19,8	156	30,6	0,319	204
101,6	2,5	6,11	7,78	95,6	3,50	18,8	24,6	191	37,6	0,319	164
101,6	3,0	7,29	9,29	113	3,49	22,3	29,2	226	44,5	0,319	137
101,6	4,0	9,83	12,3	146	3,45	28,8	38,1	293	57,6	0,319	104
101,6	5,0	11,9	15,2	177	3,42	34,9	46,7	355	69,9	0,319	84,0
101,6	6,0	14,1	18,0	207	3,39	40,7	54,9	413	81,4	0,319	70,7
101,6	6,3	14,8	18,9	216	3,38	42,3	57,3	430	84,7	0,319	67,5
114,3	2,5	6,89	8,78	137	3,95	24,0	31,3	275	48,0	0,359	145
114,3	3,0	8,23	10,5	163	3,94	28,4	37,2	325	56,9	0,359	121
114,3	4,0	10,9	13,9	211	3,90	36,9	48,7	422	73,9	0,359	91,9
114,3	5,0	13,5	17,2	257	3,87	45,0	59,8	514	89,9	0,359	74,2
114,3	6,0	16,0	20,4	300	3,83	52,6	70,4	600	109	0,359	62,4

EN 10219-2:2006 (E)

Specified outside diameter	Specified thickness	Mass per unit length	Cross-sectional area	Second moment of area	Radius of gyration	Elastic section modulus	Plastic section modulus	Torsional inertia constant	Torsional modulus constant	Superficial area per metre length	Nominal length per tonne
D	T	M	A	I	r	W_{el}	W_{pl}	I_x	C_t	A_s	
mm	mm	kg/m	cm ²	cm ⁴	cm	cm ³	cm ³	cm ⁴	cm ³	m ² /m	m
114,3	6,3	16,8	21,4	313	3,82	54,7	73,6	625	109	0,359	59,6
114,3	8,0	21,0	26,7	379	3,77	66,4	90,6	759	133	0,359	47,7
139,7	3,0	10,1	12,9	301	4,83	43,1	56,1	602	86,2	0,439	98,9
139,7	4,0	13,4	17,1	393	4,80	56,2	73,7	786	112	0,439	74,7
139,7	5,0	16,8	21,2	481	4,77	68,9	90,8	961	138	0,439	60,2
139,7	6,0	19,8	25,2	564	4,73	80,8	107	1129	162	0,439	50,5
139,7	6,3	20,7	26,4	589	4,72	84,3	112	1177	169	0,439	48,2
139,7	8,0	26,0	33,1	720	4,66	103	139	1441	206	0,439	38,5
139,7	10,0	32,0	40,7	862	4,60	123	169	1724	247	0,439	31,3
168,3	3,0	12,2	15,6	532	5,85	63,3	82,0	1066	127	0,529	81,8
168,3	4,0	16,2	20,6	697	5,81	82,8	108	1394	165	0,529	61,7
168,3	5,0	20,1	25,7	856	5,78	102	133	1712	203	0,529	49,7
168,3	6,0	24,0	30,6	1009	5,74	120	158	2017	240	0,529	41,6
168,3	6,3	25,2	32,1	1053	5,73	125	165	2107	250	0,529	39,7
168,3	8,0	31,6	40,3	1297	5,67	154	206	2595	308	0,529	31,6
168,3	10,0	39,0	49,7	1564	5,61	186	251	3128	372	0,529	25,6
177,8	4,0	17,1	21,8	825	6,15	92,8	121	1650	186	0,559	58,3
177,8	5,0	21,3	27,1	1014	6,11	114	149	2028	228	0,559	46,9
177,8	6,0	25,4	32,4	1196	6,08	135	177	2392	269	0,559	39,3
177,8	6,3	26,6	33,9	1250	6,07	141	185	2499	281	0,559	37,5
177,8	8,0	33,5	42,7	1541	6,01	173	231	3083	347	0,559	29,9
177,8	10,0	41,4	52,7	1882	5,94	209	282	3724	419	0,559	24,2
177,8	12,0	49,1	62,6	2159	5,88	243	330	4318	486	0,559	20,4
177,8	12,5	51,0	64,9	2230	5,86	251	342	4460	502	0,559	19,8
193,7	4,0	18,7	23,9	1073	6,71	111	144	2146	222	0,609	53,4
193,7	5,0	23,3	29,6	1320	6,67	136	178	2640	273	0,609	43,0
193,7	6,0	27,8	35,4	1560	6,64	161	211	3119	322	0,609	36,0
193,7	6,3	29,1	37,1	1630	6,63	168	221	3260	337	0,609	34,3
193,7	8,0	38,6	46,7	2016	6,57	208	276	4031	416	0,609	27,3
193,7	10,0	48,3	57,7	2442	6,50	252	338	4883	504	0,609	22,1
193,7	12,0	58,8	68,5	2839	6,44	293	397	5678	586	0,609	18,6
193,7	12,5	55,9	71,2	2934	6,42	303	411	5869	606	0,609	17,9
219,1	4,0	21,2	27,0	1564	7,61	143	185	3128	286	0,688	47,1
219,1	5,0	26,4	33,6	1928	7,57	176	229	3856	352	0,688	37,9
219,1	6,0	31,5	40,2	2282	7,54	208	273	4564	417	0,688	31,7
219,1	6,3	33,1	42,1	2386	7,53	218	285	4772	436	0,688	30,2
219,1	8,0	41,6	53,1	2960	7,47	270	357	5919	540	0,688	24,0
219,1	10,0	51,6	65,7	3598	7,40	328	438	7197	657	0,688	19,4
219,1	12,0	61,3	78,1	4200	7,33	383	515	8400	767	0,688	16,3
219,1	12,5	63,7	81,1	4345	7,32	397	534	8689	793	0,688	15,7
244,5	5,0	29,5	37,6	2699	9,47	221	287	5397	441	0,768	33,9
244,5	6,0	35,3	45,0	3199	9,43	262	341	6397	523	0,768	28,3
244,5	6,3	37,0	47,1	3346	9,42	274	358	6692	547	0,768	27,0
244,5	8,0	46,7	59,4	4160	9,37	340	448	8321	681	0,768	21,4
244,5	10,0	57,8	73,7	5073	9,30	415	550	10150	830	0,768	17,3
244,5	12,0	68,8	87,7	5936	9,23	486	649	11880	972	0,768	14,5
244,5	12,5	71,5	91,1	6147	9,21	503	673	12300	1006	0,768	14,0
273,0	5,0	33,0	42,1	3781	9,48	277	359	7582	554	0,858	30,3
273,0	6,0	39,5	50,3	4487	9,44	329	428	8974	657	0,858	25,3
273,0	6,3	41,4	52,8	4696	9,43	344	448	9392	688	0,858	24,1
273,0	8,0	52,3	66,6	5852	9,37	429	562	11700	857	0,858	19,1
273,0	10,0	64,9	82,6	7154	9,31	524	682	14310	1048	0,858	15,4
273,0	12,0	77,2	98,4	8396	9,24	616	818	16790	1230	0,858	12,9
273,0	12,5	80,3	102	8697	9,22	637	849	17400	1274	0,858	12,5
323,9	5,0	39,3	50,1	6389	11,3	393	509	12740	787	1,02	25,4
323,9	6,0	47,0	59,9	7572	11,2	468	606	15150	935	1,02	21,3
323,9	6,3	49,3	62,9	7928	11,2	490	636	15860	979	1,02	20,3
323,9	8,0	62,3	79,4	9910	11,2	612	799	19820	1224	1,02	16,0
323,9	10,0	77,4	98,6	12160	11,1	751	966	24320	1501	1,02	12,9
323,9	12,0	92,3	118	14320	11,0	884	1168	28640	1768	1,02	10,8
323,9	12,5	96,0	122	14650	11,0	917	1213	29690	1833	1,02	10,4
356,6	5,0	43,2	55,1	8464	12,4	476	615	16930	952	1,12	23,1

EN 10219-2:2006 (E)

Specified outside diameter	Specified thickness	Mass per unit length	Cross-sectional area	Second moment of area	Radius of gyration	Elastic section modulus	Plastic section modulus	Torsional inertia constant	Torsional modulus constant	Superficial area per metre length	Nominal length per tonne
D	T	M	A	I	r	W _{el}	W _{pl}	I _t	C _t	A _s	m
mm	mm	kg/m	cm ²	cm ⁴	cm	cm ³	cm ³	cm ⁴	cm ³	m ² /m	m
355.6	6.0	51.7	85.9	10070	12.4	568	733	20140	1133	1.12	19.3
355.6	6.3	54.3	89.1	10550	12.4	593	769	21090	1186	1.12	18.4
355.6	8.0	68.8	87.4	13200	12.3	742	967	28400	1485	1.12	14.6
355.6	10.0	86.2	109	16220	12.2	912	1195	32450	1825	1.12	11.7
355.6	12.0	102	130	19140	12.2	1076	1417	36280	2153	1.12	9.83
355.6	12.5	106	136	19850	12.1	1117	1472	39700	2233	1.12	9.45
355.6	15.0	134	171	24660	12.0	1387	1847	49330	2774	1.12	7.48
355.6	20.0	168	211	29800	11.9	1676	2255	59580	3351	1.12	6.04
406.4	6.0	59.2	75.5	15130	14.2	745	962	30260	1489	1.28	16.9
406.4	6.3	62.2	79.2	15850	14.1	760	1009	31700	1560	1.28	16.1
406.4	8.0	78.6	100	19870	14.1	978	1270	39750	1956	1.28	12.7
406.4	10.0	97.8	125	24480	14.0	1205	1572	48950	2409	1.28	10.2
406.4	12.0	117	149	28940	14.0	1424	1867	57870	2848	1.28	8.57
406.4	12.5	121	155	30030	13.9	1478	1940	60060	2956	1.28	8.24
406.4	15.0	154	196	37450	13.8	1843	2410	74900	3686	1.28	6.49
406.4	20.0	191	243	45430	13.7	2236	2989	90860	4472	1.28	5.25
406.4	25.0	235	300	54700	13.5	2692	3642	109400	5384	1.28	4.26
457.0	6.0	66.7	85.0	21620	15.9	946	1220	43240	1892	1.44	15.0
457.0	6.3	70.0	89.2	22650	15.9	991	1280	45310	1983	1.44	14.3
457.0	8.0	88.6	113	28450	15.9	1245	1613	56900	2490	1.44	11.3
457.0	10.0	110	140	35090	15.8	1536	1995	70180	3071	1.44	9.07
457.0	12.0	132	168	41580	15.7	1819	2377	83110	3637	1.44	7.59
457.0	12.5	137	175	43150	15.7	1888	2470	86290	3776	1.44	7.30
457.0	15.0	174	222	53980	15.6	2361	3113	107900	4723	1.44	5.75
457.0	20.0	216	275	65680	15.5	2874	3822	131400	5749	1.44	4.64
457.0	25.0	266	339	79420	15.3	3475	4671	158300	6951	1.44	3.75
457.0	30.0	318	402	92170	15.1	4034	5479	184400	8068	1.44	3.17
508.0	6.0	74.3	94.6	29810	17.7	1174	1512	59620	2347	1.60	13.5
508.0	6.3	77.9	99.3	31250	17.7	1230	1586	62490	2460	1.60	12.8
508.0	8.0	98.6	126	39290	17.7	1546	2000	78580	3093	1.60	10.1
508.0	10.0	123	156	48520	17.8	1910	2480	97040	3820	1.60	8.14
508.0	12.0	147	187	57540	17.5	2285	2953	115100	4530	1.60	6.81
508.0	12.5	153	195	59760	17.5	2353	3070	119500	4705	1.60	6.55
508.0	15.0	194	247	74910	17.4	2949	3874	149800	5898	1.60	5.15
508.0	20.0	241	307	91430	17.3	3600	4768	182900	7199	1.60	4.15
508.0	25.0	298	379	111000	17.1	4367	5837	221800	8734	1.60	3.36
508.0	30.0	354	451	129200	16.9	5086	6864	258400	10170	1.60	2.83
610.0	6.0	89.4	114	51920	21.4	1702	2189	103900	3405	1.92	11.2
610.0	6.3	93.8	119	54440	21.3	1785	2296	108900	3570	1.92	10.7
610.0	8.0	119	151	68550	21.3	2248	2899	137100	4495	1.92	8.42
610.0	10.0	148	188	84850	21.2	2782	3600	169700	5584	1.92	6.76
610.0	12.0	177	225	100800	21.1	3305	4292	201700	6611	1.92	5.65
610.0	12.5	184	235	104800	21.1	3435	4463	209000	6869	1.92	5.43
610.0	15.0	234	299	131800	21.0	4321	5547	263600	8541	1.92	4.27
610.0	20.0	291	371	161500	20.9	5295	6965	323000	10590	1.92	3.44
610.0	25.0	361	459	196900	20.7	6456	8561	393800	12910	1.92	2.77
610.0	30.0	429	547	230500	20.5	7857	10100	461000	15110	1.92	2.33
711.0	6.0	104	133	82570	24.9	2323	2982	165100	4645	2.23	9.59
711.0	6.3	109	139	86590	24.9	2435	3129	173200	4871	2.23	9.13
711.0	8.0	139	177	109200	24.9	3071	3954	218300	6141	2.23	7.21
711.0	10.0	173	220	135300	24.8	3806	4914	270600	7612	2.23	5.78
711.0	12.0	207	264	161000	24.7	4529	5864	322000	9057	2.23	4.83
711.0	12.5	215	274	167300	24.7	4707	6099	334700	9416	2.23	4.64
711.0	15.0	274	349	211000	24.6	5936	7730	422100	11870	2.23	3.65
711.0	20.0	341	434	259400	24.4	7295	9562	518700	14590	2.23	2.93
711.0	25.0	423	539	317400	24.3	8927	11770	634700	17850	2.23	2.36
711.0	30.0	504	642	372800	24.1	10490	13920	745600	21000	2.23	1.88
762.0	6.0	112	143	101800	26.7	2672	3429	20360	5345	2.39	8.94
762.0	6.3	117	150	106800	26.7	2803	3598	213600	5605	2.39	8.52
762.0	8.0	149	190	134700	26.7	3535	4548	269400	7073	2.39	6.72
762.0	10.0	185	236	167000	26.5	4384	5565	334100	8768	2.39	5.39
762.0	12.0	222	283	198900	26.5	5219	6751	397700	10440	2.39	4.51

EN 10219-2:2006 (E)

Specified outside diameter	Specified thickness	Mass per unit length	Cross-sectional area	Second moment of area	Radius of gyration	Elastic section modulus	Plastic section modulus	Torsional inertia constant	Torsional modulus constant	Superficial area per metre length	Nominal length per tonne
D	T	M	A	I_x	r	W_{el}	W_{pl}	I_t	C_t	A_s	
mm	mm	kg/m	cm ²	cm ⁴	cm	cm ³	cm ³	cm ⁴	cm ³	m ² /m	m
762.0	12.5	231	294	206700	26.5	5426	7023	413500	10900	2.39	4.33
762.0	15.0	294	375	251000	26.4	6850	8906	522000	13700	2.39	3.40
762.0	20.0	366	466	321100	26.2	8427	11000	642200	16860	2.39	2.73
762.0	25.0	454	579	393500	26.1	10327	13580	786900	20550	2.39	2.20
762.0	30.0	542	690	462900	25.9	12148	15080	925700	24300	2.39	1.85
813.0	8.0	159	202	163900	28.5	4032	5184	327800	8084	2.55	6.30
813.0	10.0	198	252	203400	28.4	5003	6448	406700	10010	2.55	5.05
813.0	12.0	237	302	242200	28.3	5968	7700	484500	11930	2.55	4.22
813.0	12.5	247	314	251900	28.3	6196	8011	503700	12400	2.55	4.05
813.0	16.0	314	401	318200	28.2	7828	10170	636400	15660	2.55	3.18
813.0	20.0	391	498	392000	28.0	9641	12500	783600	19280	2.55	2.56
813.0	25.0	486	619	480900	27.9	11829	15530	961700	23680	2.55	2.05
813.0	30.0	579	738	566400	27.7	13933	18400	1139000	27870	2.55	1.73
914.0	8.0	179	228	233700	32.0	5113	6567	467300	10250	2.87	5.59
914.0	10.0	223	284	290200	32.0	6349	8172	580300	12700	2.87	4.49
914.0	12.0	267	340	345890	31.9	7569	9764	691800	15140	2.87	3.75
914.0	12.5	278	354	359700	31.9	7871	10160	719400	15740	2.87	3.80
914.0	16.0	354	451	455100	31.8	9959	12900	910300	19920	2.87	2.92
914.0	20.0	441	562	561500	31.6	12268	15990	1123000	24570	2.87	2.27
914.0	25.0	548	698	690300	31.4	15105	19760	1381900	30210	2.87	1.82
914.0	30.0	654	833	814800	31.3	17829	23450	1630000	35880	2.87	1.53
1016.0	8.0	199	253	321800	35.6	6334	8126	6436000	12570	3.19	5.03
1016.0	10.0	248	318	399900	35.6	7871	10120	799700	15740	3.19	4.03
1016.0	12.0	297	378	477000	35.5	9389	12100	964000	18760	3.19	3.37
1016.0	12.5	309	394	496100	35.5	9766	12590	992300	19530	3.19	3.23
1016.0	16.0	395	503	625500	35.4	12372	16000	1257000	24740	3.19	2.53
1016.0	20.0	491	626	776300	35.2	15282	19840	1553000	30560	3.19	2.04
1016.0	25.0	611	778	958000	35.0	18821	24560	1912000	37640	3.19	1.64
1016.0	30.0	729	929	1130000	34.9	22251	29180	2261000	44600	3.19	1.37
1067.0	10.0	261	332	463900	37.4	8693	11170	927600	17390	3.35	3.84
1067.0	12.0	312	398	553420	37.3	10373	13360	1107000	20750	3.35	3.20
1067.0	12.5	325	414	575700	37.3	10790	13900	1151000	21580	3.35	3.08
1067.0	16.0	416	528	729600	37.2	13876	17680	1459000	27350	3.35	2.41
1067.0	20.0	516	658	901800	37.0	16903	21930	1804000	33810	3.35	1.94
1067.0	25.0	642	818	1111000	36.9	20831	27160	2223000	41660	3.35	1.56
1067.0	30.0	767	977	1315000	36.7	24646	32270	2630000	49290	3.35	1.30
1168.0	10.0	286	364	609500	40.9	10443	13410	1220000	20890	3.67	3.50
1168.0	12.0	342	436	726100	40.9	12467	16040	1458000	24930	3.67	2.92
1168.0	12.5	356	454	757400	40.9	12969	16690	1515000	25940	3.67	2.81
1168.0	16.0	455	579	960800	40.7	16452	21240	1922000	32900	3.67	2.20
1168.0	20.0	566	721	1189000	40.6	20363	26360	2377000	40710	3.67	1.77
1168.0	25.0	705	896	1467000	40.4	25115	32670	2933000	50230	3.67	1.42
1219.0	10.0	298	380	684000	42.7	11387	14620	1388000	22770	3.83	3.35
1219.0	12.0	367	465	828700	42.7	13597	17480	1657000	27190	3.83	2.80
1219.0	12.5	372	474	862200	42.7	14146	18200	1724000	28290	3.83	2.69
1219.0	16.0	475	605	1094000	42.5	17951	23260	2188000	35900	3.83	2.11
1219.0	20.0	591	753	1354000	42.4	22217	28760	2708400	44440	3.83	1.69
1219.0	25.0	736	938	1672000	42.2	27430	35650	3344000	54860	3.83	1.36

EN 10219-2:2006 (E)

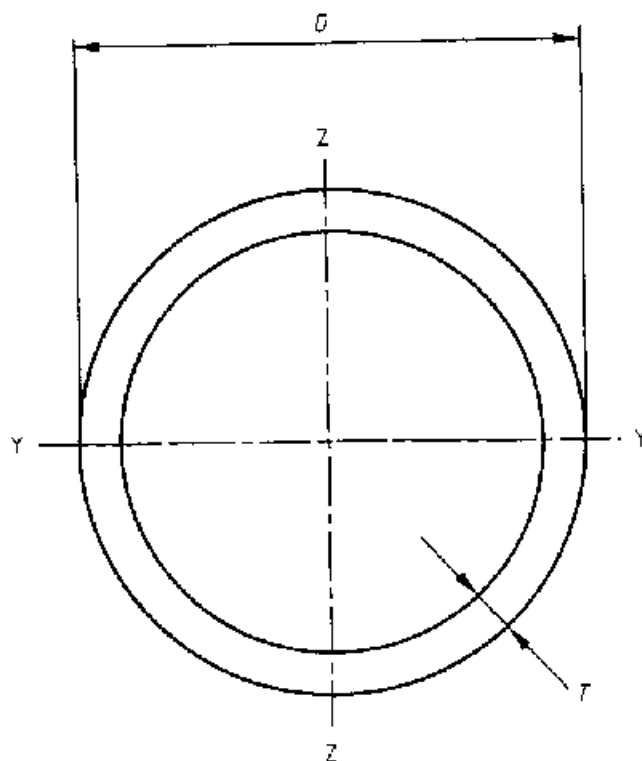

Figure C.1 — Circular hollow section

EN 10219-2:2006 (E)

Table C.2 — Nominal dimensions and sectional properties of a limited range of square hollow sections (see Figure C.2)

Specified side dimension	Specified thickness	Mass per unit length	Cross-sectional area	Second moment of area	Radius of gyration	Elastic section modulus	Plastic section modulus	Torsional inertia constant	Torsional modulus constant	Superficial area per metre length	Nominal length per tonne
B	T	M	A	J	r	W _{el}	W _{pl}	I _t	C _t	a _f	n
mm	mm	kg/m	cm ²	cm ⁴	cm	cm ³	cm ³	cm ⁴	cm ³	m ² /m	m
20	2,0	1,05	1,34	0,692	0,720	0,692	0,877	1,21	1,06	0,0731	953
25	2,0	1,36	1,74	1,48	0,924	1,19	1,47	2,53	1,80	0,0931	733
25	2,5	1,64	2,09	1,69	0,999	1,35	1,71	2,97	2,07	0,0914	610
25	3,0	1,89	2,41	1,84	0,874	1,47	1,91	3,33	2,27	0,0897	529
30	2,0	1,68	2,14	2,72	1,13	1,81	2,21	4,84	2,75	0,113	596
30	2,5	2,03	2,59	3,16	1,10	2,10	2,61	5,40	3,20	0,11	492
30	3,0	2,36	3,01	3,50	1,08	2,34	2,96	6,15	3,58	0,110	423
40	2,0	2,31	2,94	6,94	1,54	3,47	4,13	11,3	5,23	0,153	434
40	2,5	2,82	3,69	8,22	1,51	4,11	4,97	13,6	6,21	0,151	355
40	3,0	3,30	4,27	9,32	1,49	4,66	5,72	15,8	7,27	0,150	303
40	4,0	4,20	5,35	11,1	1,44	5,54	7,01	19,4	8,48	0,148	238
50	2,0	2,93	3,74	14,1	1,95	5,66	6,66	22,6	8,51	0,183	341
50	2,5	3,60	4,59	16,9	1,92	6,78	8,07	27,5	10,2	0,191	278
50	3,0	4,25	5,41	19,5	1,90	7,79	9,39	32,1	11,8	0,190	238
50	4,0	5,45	6,95	23,7	1,85	9,49	11,7	40,4	14,4	0,186	183
50	5,0	6,56	8,36	27,0	1,80	10,8	13,7	47,5	16,8	0,183	152
60	2,0	3,58	4,54	25,1	2,35	8,38	9,79	39,8	12,6	0,233	281
60	2,5	4,39	5,59	30,3	2,33	10,1	11,9	46,7	15,2	0,231	228
60	3,0	5,19	6,61	36,1	2,31	11,7	14,0	57,1	17,7	0,230	193
60	4,0	6,71	8,56	43,6	2,26	14,5	17,6	72,6	22,0	0,226	149
60	5,0	8,13	10,4	50,5	2,21	16,8	20,9	86,4	25,6	0,223	123
60	6,0	9,45	12,0	56,1	2,16	18,7	23,7	98,4	28,6	0,219	106
60	6,3	9,55	12,2	54,4	2,11	18,1	23,4	100	28,8	0,213	105
70	2,5	5,17	6,59	49,4	2,74	14,1	16,5	78,5	21,2	0,271	193
70	3,0	6,13	7,81	57,5	2,71	16,4	19,4	92,4	24,7	0,270	163
70	4,0	7,97	10,1	72,1	2,67	20,6	24,8	119	31,1	0,266	128
70	5,0	9,70	12,4	84,6	2,62	24,2	29,6	142	36,7	0,263	103
70	6,0	11,3	14,4	95,2	2,57	27,2	33,8	163	41,4	0,259	86,3
70	6,3	11,5	14,7	93,8	2,53	26,8	33,8	168	42,1	0,253	86,7
80	3,0	7,07	9,01	87,8	3,12	22,0	25,8	140	33,0	0,310	141
80	4,0	9,22	11,7	111	3,07	27,8	33,1	180	41,8	0,308	108
80	5,0	11,3	14,4	131	3,03	32,9	39,7	218	49,7	0,303	88,7
80	6,0	13,2	16,8	149	2,98	37,3	45,6	252	56,6	0,299	75,7
80	6,3	13,5	17,2	149	2,94	37,1	46,1	261	57,9	0,293	74,0
80	8,0	16,4	20,8	168	2,84	42,1	53,9	307	66,6	0,286	61,1
90	3,0	9,01	10,2	127	3,53	26,3	33,0	201	42,5	0,350	125
90	4,0	10,5	13,3	162	3,48	36,0	42,6	261	54,2	0,346	95,4
90	5,0	12,8	16,4	193	3,43	42,9	51,4	316	64,7	0,343	77,9
90	6,0	15,1	19,2	220	3,39	49,0	59,5	368	74,2	0,339	66,2
90	6,3	15,5	19,7	221	3,35	49,1	60,3	382	76,2	0,333	64,6
90	8,0	18,9	24,0	255	3,25	56,6	71,3	456	88,8	0,328	53,0
100	3,0	8,96	11,4	177	3,94	35,4	41,2	279	53,2	0,390	112
100	4,0	11,7	14,9	226	3,89	45,3	53,3	362	68,1	0,388	85,2
100	5,0	14,4	18,4	271	3,84	54,2	64,6	441	81,7	0,383	69,4
100	6,0	17,0	21,6	311	3,79	62,3	75,1	514	94,1	0,379	58,9
100	6,3	17,5	22,2	314	3,76	62,8	76,4	538	97,0	0,373	57,3
100	8,0	21,4	27,2	366	3,67	73,2	91,1	645	114	0,366	48,8
100	10,0	26,6	32,6	411	3,55	82,2	106	750	130	0,357	39,1
100	12,0	28,3	36,1	408	3,36	81,6	110	794	136	0,338	35,3
100	12,5	29,1	37,0	410	3,33	82,1	111	804	137	0,336	34,4
120	3,0	10,8	13,8	312	4,76	52,1	50,2	488	78,2	0,470	92,3
120	4,0	14,2	18,1	402	4,71	67,0	78,3	637	101	0,466	70,2
120	5,0	17,5	22,4	465	4,66	80,9	95,4	778	122	0,463	57,0
120	6,0	20,7	26,4	562	4,61	93,7	112	913	141	0,459	48,2
120	6,3	21,4	27,3	572	4,58	95,3	114	955	146	0,453	48,7
120	8,0	26,4	33,5	677	4,49	113	138	1163	176	0,446	37,9
120	10,0	31,8	40,6	777	4,38	129	162	1376	203	0,437	31,4
120	12,0	35,8	45,7	806	4,20	134	174	1518	219	0,418	27,9
120	12,5	36,9	47,0	817	4,17	136	178	1551	223	0,416	27,1

EN 10219-2:2006 (E)

Specified side dimension	Specified thickness	Mass per unit length	Cross-sectional area	Second moment of area	Radius of gyration	Elastic section modulus	Plastic section modulus	Torsional inertia constant	Torsional modulus constant	Superficial area per metre length	Nominal length per tonne
D	T	M	A	I	r	W_{el}	W_p	I_t	C_t	A_s	L_n
mm	mm	kg/m	cm ²	cm ⁴	cm	cm ³	cm ³	cm ⁴	cm ²	m ² /m	m
140	4,0	16,8	21,3	652	5,52	93,1	108	1023	140	0,546	59,7
140	5,0	20,7	26,4	791	5,48	113	132	1256	170	0,543	48,3
140	6,0	24,5	31,2	920	5,43	131	155	1479	198	0,539	40,8
140	6,3	25,4	32,3	941	5,39	134	160	1550	205	0,533	39,4
140	8,0	31,4	40,0	1127	5,30	161	194	1901	248	0,526	31,8
140	10,0	38,1	48,6	1312	5,20	187	230	2274	291	0,517	28,2
140	12,0	43,4	55,3	1398	5,03	200	253	2567	322	0,498	23,1
140	12,5	44,8	57,0	1426	5,00	204	259	2634	329	0,498	22,3
150	4,0	18,0	22,9	808	5,93	108	125	1265	162	0,586	55,5
150	5,0	22,3	28,4	982	5,89	131	153	1554	197	0,583	44,9
150	6,0	26,4	33,6	1146	5,84	153	180	1833	230	0,579	37,9
150	6,3	27,4	34,8	1174	5,80	158	185	1922	239	0,573	36,6
150	8,0	33,9	43,2	1412	5,71	186	226	2364	289	0,566	29,3
150	10,0	41,3	52,6	1653	5,61	220	269	2839	341	0,557	24,2
150	12,0	47,1	60,1	1780	5,44	237	298	3231	380	0,538	21,2
150	12,5	48,7	62,0	1817	5,41	242	306	3321	389	0,536	20,6
150	16,0	58,7	74,8	2009	5,18	268	351	3830	440	0,518	17,0
160	4,0	19,3	24,5	987	6,34	123	143	1541	185	0,626	51,9
160	5,0	23,8	30,4	1202	6,29	150	176	1896	226	0,623	42,0
160	6,0	28,3	38,0	1406	6,25	176	206	2239	264	0,619	35,4
160	6,3	29,3	37,4	1442	6,21	180	213	2349	275	0,613	34,1
160	8,0	36,5	46,4	1741	6,12	218	260	2897	334	0,606	27,4
160	10,0	44,4	56,6	2048	6,02	258	311	3490	395	0,597	22,5
160	12,0	50,9	64,9	2224	5,88	278	346	3997	443	0,578	19,5
160	12,5	52,6	67,0	2275	5,83	284	356	4114	455	0,576	19,0
160	16,0	63,7	81,2	2548	5,60	318	413	4799	520	0,558	15,7
180	4,0	21,8	27,7	1422	7,18	158	182	2210	237	0,706	45,9
180	5,0	27,0	34,4	1737	7,11	193	224	2724	290	0,703	37,1
180	6,0	32,1	43,8	2037	7,06	226	264	3223	340	0,699	31,2
180	6,3	33,3	42,4	2096	7,03	233	273	3383	354	0,693	30,0
180	8,0	41,5	52,8	2546	6,94	283	336	4189	432	0,686	24,1
180	10,0	50,7	64,6	3017	6,84	335	404	5074	515	0,677	19,7
180	12,0	58,5	74,5	3322	6,68	369	454	5865	584	0,658	17,1
180	12,5	60,5	77,0	3406	6,65	378	467	6050	600	0,656	16,5
180	16,0	73,8	94,0	3887	6,43	432	550	7178	698	0,638	13,6
200	4,0	24,3	30,9	1968	7,97	197	226	3049	295	0,786	41,2
200	5,0	30,1	38,4	2410	7,93	241	279	3783	362	0,783	33,2
200	6,0	35,8	45,6	2833	7,88	283	330	4459	426	0,779	27,9
200	6,3	37,2	47,4	2922	7,85	292	341	4682	444	0,773	26,8
200	8,0	46,5	59,2	3566	7,76	367	421	5815	544	0,766	21,8
200	10,0	57,0	72,6	4251	7,65	425	508	7072	651	0,757	17,8
200	12,0	66,0	84,1	4730	7,50	473	576	8230	743	0,738	15,2
200	12,5	68,3	87,0	4859	7,47	486	594	8502	765	0,736	14,6
200	16,0	83,8	107	5625	7,26	562	706	10210	901	0,718	11,9
220	5,0	33,2	42,4	3238	8,74	294	340	5038	442	0,863	30,1
220	6,0	39,6	50,4	3813	8,70	347	402	5976	521	0,859	25,3
220	6,3	41,2	52,5	3940	8,66	358	417	6277	543	0,853	24,3
220	8,0	51,5	65,6	4828	8,58	439	516	7815	668	0,846	19,4
220	10,0	63,2	80,8	5762	8,47	526	625	9533	804	0,837	15,8
220	12,0	73,5	93,7	6487	8,32	590	712	11150	922	0,818	13,6
220	12,5	75,2	97,0	6674	8,29	607	735	11530	951	0,816	13,1
220	16,0	93,9	120	7812	8,08	710	881	13970	1129	0,798	10,7
250	5,0	38,0	48,4	4805	9,97	384	442	7443	577	0,983	26,3
250	6,0	45,2	57,6	5672	9,92	454	524	8843	681	0,979	22,1
250	6,3	47,1	60,0	5873	9,89	470	544	9290	711	0,973	21,2
250	8,0	58,1	75,2	7229	9,80	578	676	11600	878	0,966	16,9
250	10,0	72,7	92,6	8707	9,70	697	822	14250	1062	0,957	13,8
250	12,0	84,8	108	9859	9,55	789	944	16690	1226	0,938	11,8
250	12,5	88,0	112	10160	9,52	813	975	17280	1288	0,936	11,4
250	16,0	109	139	12050	9,32	964	1180	21150	1520	0,918	9,18
260	6,0	47,1	60,0	8406	10,3	493	569	9970	739	1,02	21,2
260	6,3	49,1	62,6	8635	10,3	510	591	10480	772	1,01	20,4

EN 10219-2:2006 (E)

Specified side dimension	Specified thickness	Mass per unit length	Cross-sectional area	Second moment of area	Radius of gyration	Elastic section modulus	Plastic section modulus	Torsional inertia constant	Torsional modulus constant	Superficial area per metre length	Nominal length per tonne
R	t	M	A	I	r	W_{el}	W_{pl}	I_t	C_t	A_s	
mm	mm	kg/m	cm ²	cm ⁴	cm	cm ³	cm ³	cm ⁴	cm ³	m ² /m	m
250	8,0	81,6	78,4	8178	10,2	629	734	13090	956	1,01	16,2
260	10,0	75,8	96,6	9865	10,1	759	894	16040	1156	0,997	13,2
260	12,0	88,8	113	11200	9,96	862	1028	18880	1337	0,978	11,3
260	12,5	91,9	117	11560	9,93	888	1063	19550	1381	0,976	10,9
260	16,0	114	145	13740	9,73	1057	1289	23990	1663	0,958	8,77
300	6,0	54,7	69,6	9964	12,0	684	764	15430	997	1,18	8,3
300	6,3	57,0	72,6	10340	11,9	689	795	16220	1042	1,17	17,5
300	8,0	71,6	91,2	12800	11,8	853	991	20310	1293	1,17	14,0
300	10,0	88,4	113	15520	11,7	1035	1211	24970	1572	1,16	11,3
300	12,0	104	132	17770	11,6	1184	1402	29510	1829	1,14	9,65
300	12,5	108	137	18350	11,6	1223	1451	30600	1892	1,14	9,30
300	16,0	134	171	22090	11,4	1472	1774	37940	2299	1,12	7,46
350	8,0	84,2	107	20680	13,9	1182	1366	32560	1787	1,37	11,9
350	10,0	104	133	25190	13,8	1439	1675	40130	2182	1,36	9,61
350	12,0	123	156	29060	13,8	1660	1949	47600	2552	1,34	8,16
350	12,5	127	162	30050	13,6	1717	2020	49390	2642	1,34	7,86
350	16,0	159	203	36510	13,4	2086	2488	61480	3238	1,32	6,28
400	10,0	120	153	38220	15,8	1911	2214	60430	2892	1,56	8,35
400	12,0	141	180	44320	15,7	2216	2587	71840	3395	1,54	7,07
400	12,5	147	187	45880	15,7	2294	2683	74600	3518	1,54	6,81
400	16,0	184	235	56150	15,5	2808	3322	93280	4336	1,52	5,43

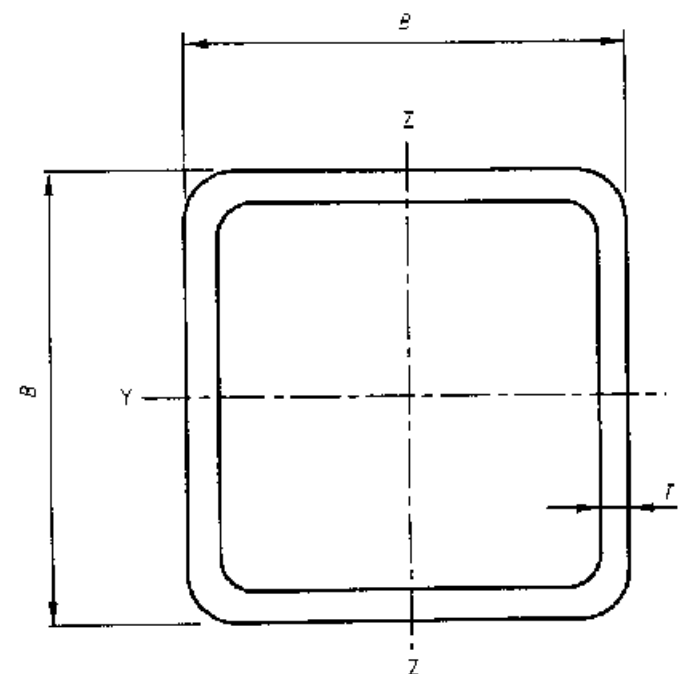

Figure C.2 — Square hollow section

EN 10219-2:2006 (E)

Table C.3 — Nominal dimensions and sectional properties of a limited range of rectangular hollow sections (see Figure C.3)

Specified side dimensions	Specified thickness	Mass per unit length	Cross sectional area	Second moment of area		Radius of gyration		Elastic section modulus		Plastic section modulus		Torsional Inertia constant	Superficial area per metre length		Nominal length per tonne	
				I_{yy}	I_{zz}	r_{yy}	r_{zz}	$W_{el,y}$	$W_{el,z}$	$W_{pl,y}$	$W_{pl,z}$		C_t	A_s		
B × H	t	M	A	I_{yy}	I_{zz}	r_{yy}	r_{zz}	$W_{el,y}$	$W_{el,z}$	$W_{pl,y}$	$W_{pl,z}$	L_t	C_t	A_s		
mm	mm	kg/m	cm ²	cm ⁴	cm ⁴	cm	cm	cm ³	cm ³	cm ³	cm ³	cm ⁴	cm ²	m ² /m	m	
40	20	2.0	1.68	2.14	4.05	1.34	1.38	0.793	2.02	1.34	2.61	1.60	3.45	2.36	0.113	596
40	20	2.0	1.68	2.14	4.05	1.34	1.38	0.793	2.02	1.34	2.61	1.60	3.45	2.36	0.113	596
40	20	2.5	2.03	2.59	4.59	1.54	1.35	0.770	2.35	1.54	3.09	1.88	4.06	2.72	0.111	492
40	20	3.0	2.35	3.01	5.21	1.68	1.32	0.748	2.60	1.68	3.50	2.12	4.57	3.00	0.110	423
50	30	2.0	2.31	2.94	9.54	4.29	1.80	1.21	3.81	2.86	4.74	3.33	9.77	4.84	0.153	434
50	30	2.5	2.82	3.59	11.3	5.05	1.77	1.19	4.52	3.37	5.70	3.98	11.7	5.72	0.151	355
50	30	3.0	3.30	4.21	12.8	5.70	1.75	1.16	5.13	3.80	6.57	4.58	13.6	6.49	0.150	303
50	30	4.0	4.20	5.35	15.3	6.89	1.69	1.12	6.10	4.46	8.05	5.58	18.5	7.71	0.146	238
60	40	2.0	2.93	3.74	18.4	9.83	2.22	1.62	6.14	4.92	7.47	5.65	20.7	8.12	0.193	341
60	40	2.5	3.60	4.59	22.1	11.7	2.19	1.60	7.36	5.87	9.06	6.84	25.1	9.72	0.191	278
60	40	3.0	4.25	5.41	25.4	13.4	2.17	1.58	8.46	6.72	10.5	7.94	29.3	11.2	0.190	236
60	40	4.0	5.45	6.95	31.0	16.3	2.11	1.53	10.3	8.14	13.2	9.89	36.7	13.7	0.186	183
60	40	5.0	6.56	8.36	35.3	18.4	2.06	1.48	11.8	9.21	15.4	11.5	42.8	15.6	0.183	152
70	50	2.0	3.56	4.54	31.5	18.8	2.63	2.03	8.99	7.50	10.8	8.58	37.5	12.2	0.233	281
70	50	2.5	4.39	5.59	38.0	22.6	2.61	2.01	10.9	9.04	13.2	10.4	45.8	14.7	0.231	228
70	50	3.0	5.19	6.61	44.1	26.1	2.58	1.99	12.6	10.4	15.4	12.2	53.6	17.1	0.230	193
70	50	4.0	6.71	8.55	54.7	32.2	2.53	1.94	15.6	12.9	19.5	15.4	68.1	21.2	0.226	149
70	50	5.0	8.13	10.4	63.5	37.2	2.48	1.90	18.1	14.9	23.1	18.2	80.8	24.6	0.223	123
80	40	2.0	3.56	4.54	37.4	12.7	2.87	1.87	9.34	6.36	11.6	7.17	30.9	11.0	0.233	281
80	40	2.5	4.39	5.59	45.1	15.3	2.84	1.85	11.3	7.63	14.1	8.72	37.6	13.2	0.231	228
80	40	3.0	5.19	6.61	52.3	17.6	2.81	1.83	13.1	8.78	16.5	10.2	43.9	15.3	0.230	193
80	40	4.0	6.71	8.55	64.8	21.5	2.75	1.79	16.2	10.7	20.9	12.8	55.2	18.8	0.226	149
80	40	5.0	8.13	10.4	75.1	24.6	2.69	1.74	18.8	12.3	24.7	15.0	65.0	21.7	0.223	123
80	60	2.0	4.19	5.34	49.5	31.9	3.05	2.44	12.4	10.6	14.7	12.1	61.2	17.1	0.273	239
80	60	2.5	5.17	6.59	60.1	38.6	3.02	2.42	15.0	12.9	18.0	14.8	75.1	20.7	0.271	193
80	60	3.0	5.13	7.81	70.0	44.9	3.00	2.40	17.5	15.0	21.2	17.4	88.3	24.1	0.270	163
80	60	4.0	7.97	10.1	87.9	56.1	2.94	2.35	22.0	18.7	27.0	22.1	113	30.3	0.266	126
80	60	5.0	9.70	12.4	103	65.7	2.89	2.31	26.8	21.9	32.2	26.4	136	36.7	0.263	103
90	50	2.0	4.19	5.34	57.9	23.4	3.29	2.09	12.9	9.35	15.7	10.5	53.4	15.9	0.273	239
90	50	2.5	5.17	6.59	70.3	28.2	3.27	2.07	15.8	11.3	19.3	12.8	65.3	19.2	0.271	193
90	50	3.0	6.13	7.81	81.9	32.7	3.24	2.05	18.2	13.1	22.6	15.0	76.7	22.4	0.270	163
90	50	4.0	7.97	10.1	103	40.7	3.18	2.00	22.8	16.3	28.8	19.1	97.7	28.0	0.266	126
90	50	5.0	9.70	12.4	121	47.4	3.12	1.96	26.8	18.9	34.4	22.7	116	32.7	0.263	103
100	40	2.5	5.17	6.59	79.3	18.8	3.47	1.69	15.9	9.39	20.2	10.6	60.5	16.8	0.271	193
100	40	3.0	6.13	7.81	92.3	21.7	3.44	1.67	18.5	10.8	23.7	12.4	69.0	19.4	0.270	163
100	40	4.0	7.97	10.1	116	26.7	3.38	1.62	23.1	13.3	30.3	15.7	74.5	24.0	0.266	126
100	40	5.0	9.70	12.4	136	30.8	3.31	1.59	27.1	15.4	36.1	18.5	87.9	27.9	0.263	103
100	50	2.5	5.56	7.09	91.2	31.1	3.59	2.09	18.2	12.4	22.7	14.0	75.4	21.5	0.291	180
100	50	3.0	6.60	8.41	106	36.1	3.56	2.07	21.3	14.4	26.7	16.4	88.6	25.0	0.290	152
100	50	4.0	8.59	10.9	134	44.9	3.50	2.03	26.8	18.0	34.1	20.9	113	31.3	0.286	116
100	50	5.0	10.5	13.4	158	52.6	3.44	1.98	31.6	21.0	40.8	25.0	135	36.8	0.283	95.4
100	50	6.0	12.3	15.6	179	59.7	3.38	1.94	35.8	23.5	46.9	28.5	154	41.4	0.279	81.5
100	50	6.3	12.5	15.9	176	58.2	3.32	1.91	35.1	23.3	46.9	28.6	158	42.1	0.273	79.9
100	60	2.5	5.96	7.59	103	46.9	3.69	2.49	20.6	16.6	25.1	17.7	103	28.2	0.311	168
100	60	3.0	7.07	9.01	121	54.6	3.66	2.46	24.1	18.2	29.6	20.8	122	30.6	0.310	141
100	60	4.0	9.22	11.7	153	68.7	3.60	2.42	30.5	22.9	37.9	26.6	156	38.7	0.306	108
100	60	5.0	11.3	14.4	181	80.8	3.55	2.37	36.2	26.9	45.6	31.9	189	45.8	0.303	89.7
100	60	6.0	13.2	16.8	205	91.2	3.49	2.33	41.1	30.4	52.5	36.6	216	51.9	0.298	75.7
100	60	6.3	13.5	17.2	203	90.9	3.44	2.30	40.7	30.3	52.8	36.9	223	53.0	0.293	74.0
100	80	2.5	6.74	8.59	127	90.2	3.84	3.24	25.4	22.6	30.0	25.8	166	35.7	0.351	146
100	80	3.0	8.01	10.2	149	106	3.82	3.22	29.8	25.4	35.4	30.4	195	41.9	0.350	125
100	80	4.0	10.5	13.3	189	134	3.77	3.17	37.9	33.5	45.6	39.2	254	53.4	0.346	95.4
100	80	5.0	12.8	16.4	226	160	3.72	3.12	45.2	39.9	55.1	47.2	308	63.7	0.343	77.9

EN 10219-2:2006 (E)

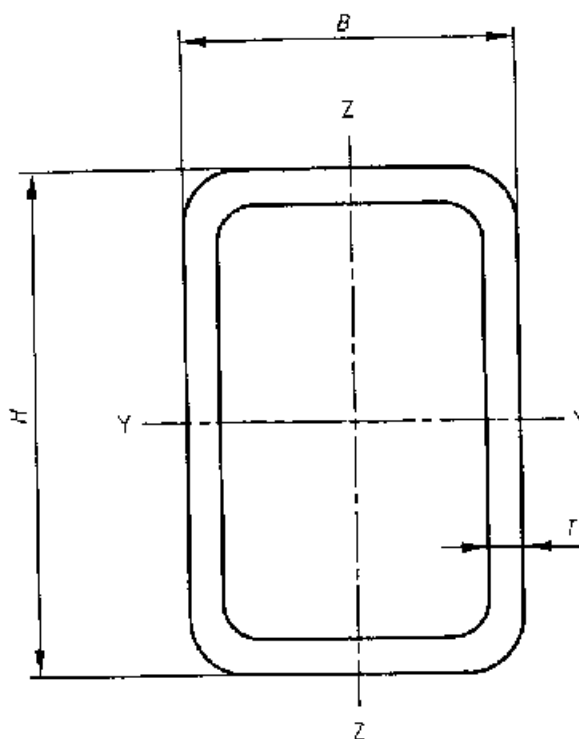

Figure C.3 — Rectangular hollow section

EN 10219-2:2006 (E)

Bibliography

ENV 1993-1-6, *Eurocode 3: Design of steel structures - Part 1-6: General rules - Supplementary rules for the shell structures*

ENV 1993-5, *Eurocode 3: Design of steel structures - Part 5: Piling*

BS EN
10219-2:2006

BSI — British Standards Institution

BSI is the independent national body responsible for preparing British Standards. It presents the UK view on standards in Europe and at the international level. It is incorporated by Royal Charter.

Revisions

British Standards are updated by amendment or revision. Users of British Standards should make sure that they possess the latest amendments or editions.

It is the constant aim of BSI to improve the quality of our products and services. We would be grateful if anyone finding an inaccuracy or ambiguity while using this British Standard would inform the Secretary of the technical committee responsible, the identity of which can be found on the inside front cover. Tel: +44 (0)20 8996 9000. Fax: +44 (0)20 8996 7400.

BSI offers members an individual updating service called PLUS which ensures that subscribers automatically receive the latest editions of standards.

Buying standards

Orders for all BSI, international and foreign standards publications should be addressed to Customer Services. Tel: +44 (0)20 8996 9001. Fax: +44 (0)20 8996 7001. Email: orders@bsi-global.com. Standards are also available from the BSI website at <http://www.bsi-global.com>.

In response to orders for international standards, it is BSI policy to supply the BSI implementation of those that have been published as British Standards, unless otherwise requested.

Information on standards

BSI provides a wide range of information on national, European and international standards through its Library and its Technical Help to Exporters Service. Various BSI electronic information services are also available which give details on all its products and services. Contact the Information Centre. Tel: +44 (0)20 8996 7111. Fax: +44 (0)20 8996 7048. Email: info@bsi-global.com.

Subscribing members of BSI are kept up to date with standards developments and receive substantial discounts on the purchase price of standards. For details of these and other benefits contact Membership Administration. Tel: +44 (0)20 8996 7002. Fax: +44 (0)20 8996 7001. Email: membership@bsi-global.com.

Information regarding online access to British Standards via British Standards Online can be found at <http://www.bsi-global.com/bsonline>.

Further information about BSI is available on the BSI website at <http://www.bsi-global.com>.

Copyright

Copyright subsists in all BSI publications. BSI also holds the copyright, in the UK, of the publications of the international standardization bodies. Except as permitted under the Copyright, Designs and Patents Act 1988 no extract may be reproduced, stored in a retrieval system or transmitted in any form or by any means – electronic, photocopying, recording or otherwise – without prior written permission from BSI.

This does not preclude the free use, in the course of implementing the standard, of necessary details such as symbols, and size, type or grade designations. If these details are to be used for any other purpose than implementation then the prior written permission of BSI must be obtained.

Details and advice can be obtained from the Copyright & Licensing Manager. Tel: +44 (0)20 8996 7070. Fax: +44 (0)20 8996 7553. Email: copyright@bsi-global.com.

BSI
389 Chiswick High Road
London
W4 4AL

КОНСТРУКЦИОННЫЕ СТАЛИ ДЛЯ ОФШОРНОГО



И НАЗЕМНОГО СТРОИТЕЛЬСТВА

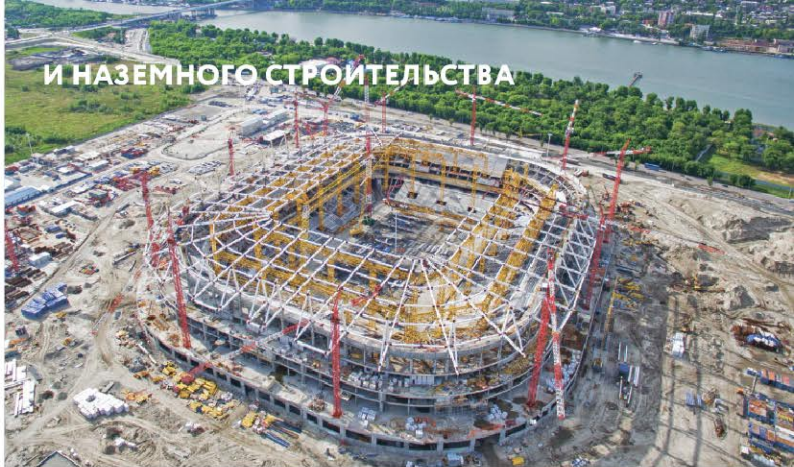

КОМПЛЕКСНЫЕ ПОСТАВКИ
НА ПРЕДПРИЯТИЯ ПИЩЕВОЙ
ПРОМЫШЛЕННОСТИ

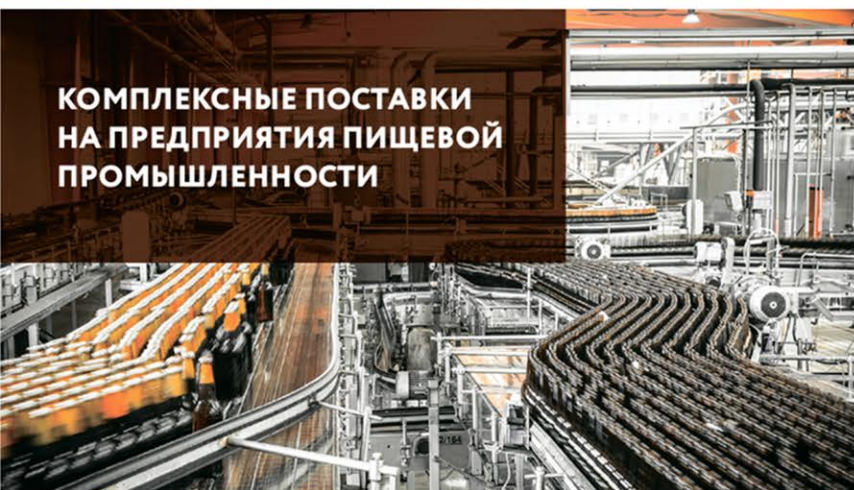

КОМПЛЕКСНЫЕ ПОСТАВКИ НА ОЛИМПИАДУ
2014 В СОЧИ И ЧЕМПИОНАТ МИРА
ПО ФУТБОЛУ 2018



КОМПЛЕКСНЫЕ ПОСТАВКИ
ДЛЯ СТРОИТЕЛЬСТВА
С НУЛЯ НА МАСШТАБНЫЕ
ПРОЕКТЫ

В КОМПАНИИ
РАБОТАЮТ
БОЛЕЕ

300

ЧЕЛОВЕК

ЭНЕРГЕТИКА
И СПЕЦИАЛЬНЫЕ ЗАКАЗЫ



Новатэк
Ямал СПГ
ЩекиноАзот
Акрон
ЕвроХим
Сибур
Лукойл
Росатом
СПГ в Калининградской области
Высоцкий СПГ
Курская АЭС
АЭС Руппур в Бангладеше
Балаковская АЭС
И другие...

ТРУБЫ И ОБВЯЗКА ДЛЯ
НЕФТЕХИМИЧЕСКОЙ И
АТОМНОЙ ПРОМЫШЛЕННОСТИ



КРУПНЕЙШИЙ ИНТЕРНЕТ-МАГАЗИН НЕРЖАВЕЙКИ
RUSSTEELS.RU

РАБОТАЕМ
С 2000 ГОДА

2000

ЗА ВСЁ ВРЕМЯ МЫ
ПОСТАВИЛИ БОЛЕЕ

200000

ТОНН НЕРЖАВЕЮЩЕГО МЕТАЛЛА

ПОСТАВКИ ЛИСТОВОГО МЕТАЛЛА
И ТРУБ ДЛЯ МАШИНОСТРОЕНИЯ



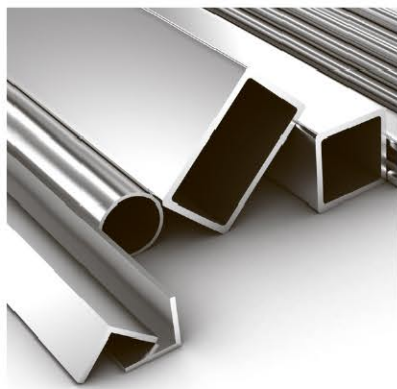

**ПОКУПАЙ
БОЛЕЕ
7000**
ВИДОВ НЕРЖАВЕЙКИ
ОНЛАЙН НА RUSSTEELS.RU



**Специальные
Стали и Сплавы**

**E-MAIL: INFO@RUSSTEELS.RU
RUSSTEELS.RU**

Щелково, +7 (495) 775-55-22
ул. Заводская, д. 14Б, пом.17

Челябинск, +7 (351) 242-01-02
пр-т Победы, д. 158, офис 407

Санкт-Петербург, +7 (812) 454-21-54
пр-т Обуховской обороны, д. 112, литера И, БЦ "ВАНТ", офис 235

Воронеж, +7 (473) 300-38-88
ул. Солнечная, 10Б, БК "Крепез", офис 210

Краснодар, +7 (861) 205-00-10
Ростовское шоссе, д. 14/2, офис 306

Самара, +7 (846) 300-44-54
Заводское шоссе, д. 111, офис 452

Нижний Новгород, +7 (831) 260-12-22
ул. Варварская, д. 32, литера Д, офис 301

Пятигорск, +7 (8793) 31-78-22
Черкесское шоссе, д. 11

